



Quality and Reliability Matter When It Comes to EV Chargers

The infrastructure for electricity is well established, with the modern electrical grid providing safe and reliable energy to homes and businesses around the world. As consumers move to electric vehicles (EVs), however, they are drawing new levels of power from the electrical grid to charge them.

At the intersection of the EV and the grid — bridging the new world and the old — are EV chargers: the electronic control box, vehicle coupler connector, cable and wall plug that together make EV charging happen. Not only does the equipment need to be tough and reliable; it also needs to be designed to safeguard against any potential hazards that could occur when interfacing with an electrical infrastructure that was never built with EVs in mind.

Higher-quality EV chargers provide superior heat management, cable robustness, drop protection and environmental protection. They protect consumers' homes from damage, they weather the elements and they last longer than lower-rated chargers. As EV consumers demand the speed and convenience associated with refueling gas-powered vehicles, a key part of the equation will be the last few meters of the grid: an EV charger that is built to withstand all kinds of conditions and power loads.

WHY RELIABILITY IS KING

Every battery electric vehicle and plug-in hybrid electric vehicle needs a charge. As EVs become more commonplace, consumers will demand reliable charging. That means home EV chargers have to be tough and safe enough to undergo daily use — charging vehicles every day, over long periods of time.

Creating a reliable charger involves both electrical and mechanical considerations.

On the electrical side, the charger’s electronic control box is there to safely watch and supply power to the vehicle, ensuring that the consumer is able to charge it as expected. The electronics must have redundant features built into their design so a component failure does not lead to a safety issue. Thermal management is crucial to protect against overheating – at both the connection to the grid and within the EV charger itself – and to optimize the charging cycle.

On the mechanical side, years of field experience have taught us that consumer use presents an

array of challenges. Not only will consumers drop EV chargers repeatedly over time, but they will also wrap the cables, drive over them and leave them out in the rain. Lawn mowers will occasionally run over them, and dogs may chew on them.

Designs must account for these mechanical challenges in every part of the charger. They should include robust cable construction that couples stress reducers with proper strain relief to prevent copper strands from breaking and cable insulation from rupturing. If there is an in-cable control box (ICCB), it must be automotive-grade and properly sealed to protect it from the elements. And the coupler — the part that consumers handle the most, as they plug it into their vehicles — has to be able to withstand repeated drops and misalignment when being plugged in.

Supplying EV chargers to the market requires, at a minimum, certifying them to safety standards such as those set by UL, the International Electrotechnical Commission (IEC) and the Care Quality Commission. One might think that

ATTENTION THROUGHOUT

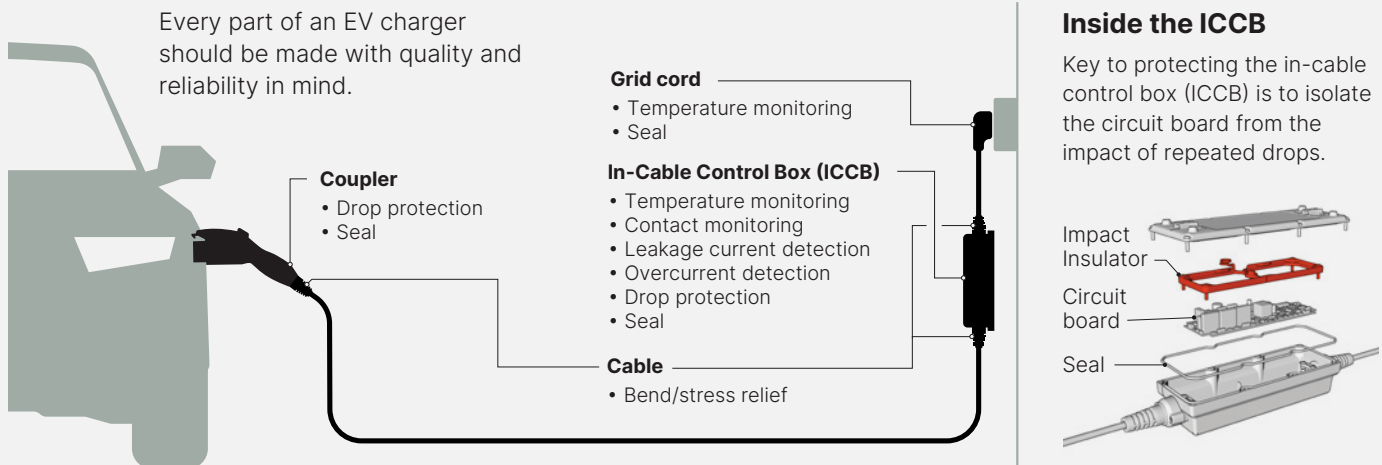

Figure 1: Features essential to EV chargers

adherence to industry standards would be enough to address reliability concerns, but most standards only ensure that a charger will be safe for use under the tested conditions. They do not ensure that the charger will continue to function optimally and reliably over time. As a result, our requirements typically exceed the minimum safety standards, focusing on designs and validations that support field reliability.

A complex field product

EVs are gaining popularity all over the world, and EV charging is developing differently for different regions and use cases. This makes for a high degree of complexity — and a lot of part numbers — for global OEMs. But there are three generally accepted descriptors for electric vehicle supply equipment (EVSE), which includes EV chargers: mode, level and type.

Mode: The mode (see Figure 2) reflects how the EVSE connects to the electrical grid.

- Mode 1 plugs into a household AC socket, but it generally is not permitted in most regions, because Mode 1 lacks special safety electronics.

- Mode 2 also plugs into a standard household AC outlet and includes those safety features in its ICCB.
- Mode 3 plugs into a wall box or charging station for an AC charge. It does not include an ICCB. Consumers are often required to bring their own Mode 3 cable to use public AC charging stations in Europe.
- Mode 4 is reserved for high-speed DC charging at charging stations.

Level: The level indicates how much electric power is delivered to the vehicle. The Society of Automotive Engineers specifies the following levels in the J1772 standard:

- Level 1 is limited to 120V and 1.8 kW and delivers basic charging.
- Level 2 is defined as 208V to 240V and up to 80A, with a maximum output of 19.2 kW. As OEMs increase battery sizes, they are also increasing the power level within this band. Typical BEVs today can take 11 kW of AC power via their onboard chargers. Homes with three-phase power installed can reach 11 kW with 16A of current, while a single-phase power source would need to supply about 48A.

EVSE CHARGING MODES

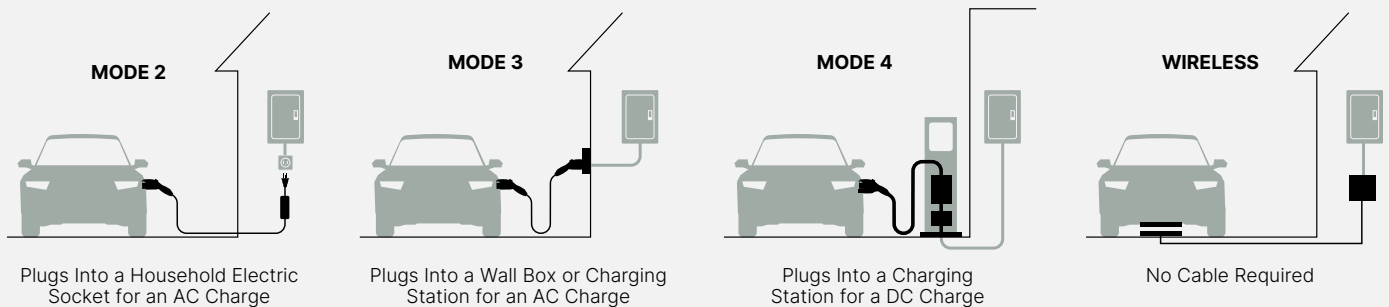

Figure 2: The mode describes how the EVSE connects to the grid.

- DC Level 1 and 2 provide fast charging and are only available at commercial stations. DC Level 2, commonly referred to as simply “Level 3,” can provide up to 1,000 VDC and is projected to reach 500A in the future, with a power output of more than 350 kW. This rate can charge about 80 percent of a typical EV battery in as little as 20 minutes.

Type: Type refers to the vehicle interface. Unfortunately, standards organizations have not aligned behind a global standard. Consequently, there are three unique interfaces for AC charging globally (see Figure 3):

- North America and Korea use J1772 Type 1 for AC and CCS1 for DC.
- Europe uses IEC Type 2 for AC and CCS2 for DC.
- Japan uses J1772 Type 1 for AC but CHAdeMO for DC.
- China uses the GB/T interface for AC and a unique DC interface.

- In addition, the emerging ChaoJi standard may be adopted in both China and Japan.

Elements of a superior EV charger

High-quality EV chargers ensure that consumers experience high degrees of reliability, toughness and safety — and provide the charge to the vehicle as expected — by addressing all of the electrical and mechanical considerations discussed previously. Here is a look at the important elements:

- **Electrical:** Redundant features, either in software or hardware, can prevent a single point of failure from creating an unsafe condition. In addition, the charger should have features that allow power to flow to the vehicle if there are system problems, perhaps at a reduced rate, so at least some charge can be achieved. And while current standards do not require contact monitors, grid cord monitors and so forth, a superior EV charger will include those to help ensure safety.

EVSE TYPES

	North America	Europe	Japan/Korea	China	NACS
AC	J1772 TYPE 1	TYPE 2	J1772 TYPE 1	GB/T	
DC	CCS TYPE 1	CCS TYPE 2	CHAdeMO	GB/T	

Figure 3: The type is the vehicle connector interface, and it varies by region.

- **Heat management:** Superior chargers can handle higher power rates, reducing the time needed for a charge. And they can do so over a wide range of ambient temperatures, typically -40° C to 50° C (-40° F to 122° F). In some areas of the world, such as the Middle East, EVSEs may have to perform at an operating temperature of 70° C if the ambient temperature is 50° C. Designs must account for these possibilities, deliver full power under extreme temperatures without derating, and react to any temperature issues to protect the system.
- **Self-monitoring:** Grid cord thermal monitoring gauges the temperature at the plug to make sure the unit is not overheating, providing protection in situations where the unit is plugged into an outlet that is compromised. Meanwhile, the ICCB should monitor its own temperature to protect the electronics in extreme conditions. Additionally, relay contact monitoring is important to detect a welded or open contact.
- **Strain and bend relief:** This helps protect against consumer abuse and normal wear and tear that can lead to cracked insulating jackets, broken cable strands and internal short circuiting. Stress-to-failure evaluation tests are a critical tool in developing a cable that can stand up to abuse. Consumers may wrap the cable around the ICCB, for example, flexing the cable tightly. To help counteract this consumer use and ensure cable reliability, strain relief for limiting a pinch area is critical.
- **Drop protection:** EV chargers are going to get dropped, and over a charger's lifetime those drops can cause damage. Developers can limit this damage by using advanced electronics isolation. An EV charger's ICCB and electronics should be able to withstand at least 100 drops unpowered and 50 drops powered from a height of 1 meter, and its coupler should be able to withstand 250 drops from the same height.
- **Sealed enclosures:** These help protect the charger and its ICCB against damage from the elements, especially water. This protection is

important for equipment use outdoors, where chargers can be damaged by rain, sleet and snow.

- **Charging capacity:** The larger the battery, the longer it takes to charge. Faster charging requires greater capacity in the vehicle's internal wiring and also in the charger. Today's low-cost chargers are able to handle only 1.4 kW to 3.6 kW. The next generation of EV chargers extend up to 11 kW, allowing for much faster charging at home.

Beyond standards

Industry standards serve an important role as the basic requirements for the commercialization of an EV charger. But meeting the standards is really just the price of admission, and some standards fall short of what is needed for the reliable performance over time that automotive OEMs require.

For example, a standard might not require thermal monitoring in grid cords. An electrical outlet in a house could have been installed decades ago, with no one having anticipated that a homeowner might someday run 12A over 10 hours through it every night to charge an EV. Without proper thermal monitoring, a degraded electrical infrastructure in the house could lead to a meltdown. Having thermal monitoring integrated into the system protects the consumer receptacle as well as the charger.

Similarly, basic standards require that an EV charger can withstand being dropped repeatedly, and the charger can pass the drop test if it does not create an unsafe condition, such as exposing a high-voltage wire. Whether the charger still functions reliably is not considered, though.

Instead of following requirements for consumer electronics components, superior EV chargers follow the Automotive Electronics Council qualifications (AEC-Q) for automotive-grade components. AEC-Q-compliant components have tighter tolerancing, testing and quality requirements and are therefore more reliable over time.

PART OF A COMPLETE SOLUTION

As society embraces electrified mobility, consumers are looking for reassurance that the related technologies work well under all circumstances. They will expect EVs to achieve a level of performance that is the same as or better than what they have come to rely on with gas-powered vehicles, and they will also look for a charging experience with the same level of safety and convenience that a refueling experience provides.

A robust charger is a key element of that reassurance. The EV charger has to work safely, and it has to work well — under adverse conditions, over long periods of time and with speed.

We are a leader in EV chargers because we understand toughness. For example, we have developed industry-leading cable robustness through aggressive test-to-failure evaluations. Our cables have performed seven times better than competing cables in these tests.

More important, we see EV chargers as part of a full picture that includes all of the electrical components in the vehicle. At the charging inlet, we are building innovations in active and passive cooling that allow for faster charging rates, and we continue to create high-voltage interconnects and wiring that give OEMs access to the higher power the market is demanding. These innovations build on our years of experience with low-voltage wiring and connectors, including highly complex wiring harnesses.

This perspective gives us a unique view of what it really means to charge an EV. We have a deep understanding of every electrical need within today's vehicles, and we have a vision of how those needs can be met through next-generation architectures

RELEVANT STANDARDS AND RATINGS

Automotive OEMs have learned that they need to establish a higher bar beyond the minimum standards for EV chargers, but here are the basic standards all chargers should meet:

- IEC 62752 in Europe
- UL 2594 in the United States
- GB/T 20334 in China
- IP67 rating for waterproof cables and connectors
- AEC-Q200 qualification standard for stress resistance in passive electronic components
- National Electrical Manufacturers Association standards for electric-component enclosures

LEARN MORE AT [VERSIGENT.COM](https://www.versigent.com) →